

# IM 10090 AC & IM 12090 AC

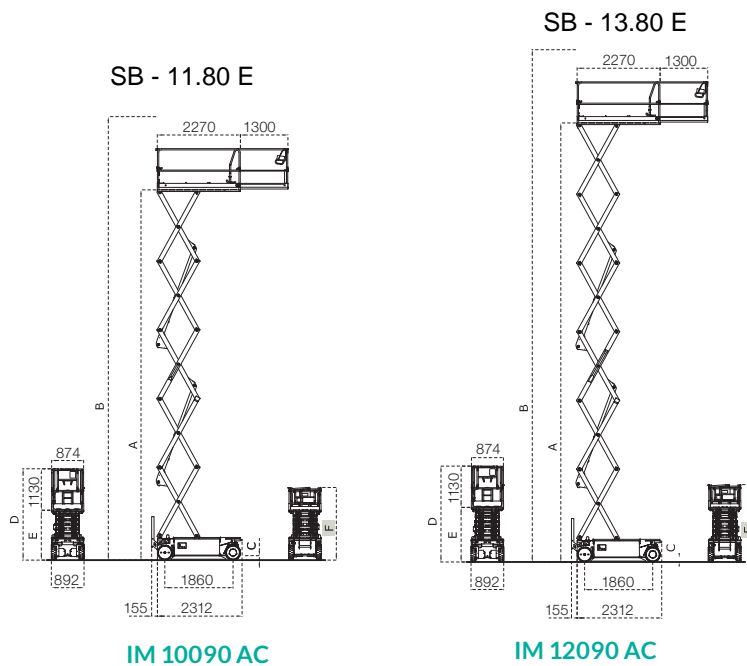

		IM 10090 AC		IM 12090 AC	
		Indoor	Outdoor	Indoor	Outdoor
Number of scissors		5	5	6	6
A (platform height)	m	10	6.3	12	7.4
B (working height)	m	12	8.3	14	9.4
C (ground clearance: pot hole up/down)	mm	120/22	120/22	120/22	120/22
D (stowed height)	m	2.49	2.49	2.62	2.62
E (min. platform height)	m	1.36	1.36	1.49	1.49
F (height with folded guards)	m	1.98	1.98	2.11	2.11
Capacity	kg	300	300	230	230
Capacity on deck extension	kg	300	300	230	230
Allowed operators	n°	3	1	2	1
Traction motors	V / kW	24/3.0	24/3.0	24/3.0	24/3.0
Powerpack	V / kW	24/3.0	24/3.0	24/3.0	24/3.0
Batteries	V/Ah	24/200		24/275	
Battery weight	kg	31.5		45	
Battery charger	V/A	24/20	24/20	24/30	24/30
Oil tank capacity	l	17	17	17	17
Max driving speed	km / h	4	4	4	4
Safety speed	km / h	0.6	0.6	0.6	0.6
Gradeability	%	25	25	25	25
Internal turning radius	m	0	0	0	0
External turning radius	m	2.22	2.22	2.22	2.22
Tires dimensions	mm	410x130	410x130	410x130	410x130
Tires type		cushion	cushion	cushion	cushion
Max side/longitudinal tilt angle	degrees	1.5/2.5	1.5/2.5	1.2/2.5	1.2/2.5
Weight	kg	2850		3180	

